

PH Pushbutton Switch

PH

Standard pushbutton switch with a lot of variations.

- Button size : 12 mm Square, 12×17.2 mm Rectangle and 10 mm Round type available.

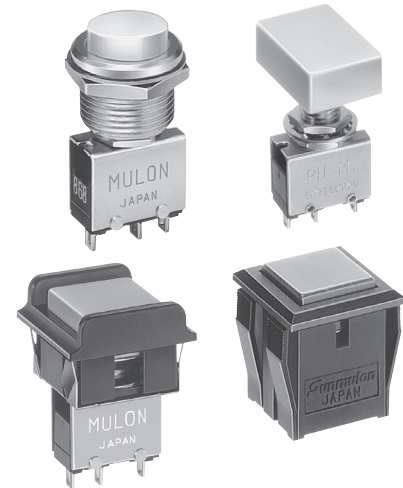
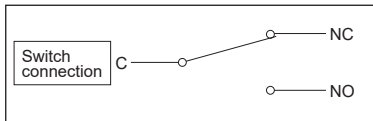

CHARACTERISTICS

Button Size	Square : □12 mm Rectangle : 12×17.2 mm Round : φ 10 mm		
Contact Material	Silver contact	Silver contact (Gold-plated)	Cross-bar contact
Rating (Resistive Load)	AC 125 V 5 A AC 250 V 5 A		AC 125 V 0.1 A DC 30 V 0.1 A
Insulation Resistance	More than 100 MΩ at DC 500 V		
Dielectric Strength	AC 1000 V RMS between NC and NO terminal AC 1500 V RMS between terminals and ground 50/60 Hz for 60 sec. at normal ambient temperature and humidity		AC 600 V RMS between NC and NO terminal AC 1500 V RMS between terminals and ground 50/60 Hz for 60 sec. at normal ambient temperature and humidity
Contact Resistance	Less than 30 mΩ (Initial value) at DC 6 V 1 A	Less than 50 mΩ (Initial value) Milliohm meter (YHP4328A)	Less than 50 mΩ (Initial value) at DC 6 V 0.1 A
Vibration Resistance	10 to 55 Hz, Amplitude 1.5 mm		
Mechanical Life	Momentary	More than 300,000 operations	
	Alternate	More than 200,000 operations	
Electrical Life (Resistive Load)	More than 50,000 operations at max. rated load		More than 100,000 operations at max. rated load
Operating Force	Momentary	SPDT : 1.96 N max. DPDT : 3.92 N max.	
	Alternate	SPDT : 2.45 N max. DPDT : 2.45 N max.	
Total Travel	Momentary	1.5 mm max.	
	Alternate	3.2 mm max.	
Weight	Square : 8 g Rectangle : 12 g Round : 12 g		
Ambient Operating Temperature	-15°C to 50°C (No Freeze, No Condensation)		
Ambient Operating Humidity	80%RH max. (No Condensation)		
Ambient Storage Temperature	-25°C to 65°C (No Freeze, No Condensation)		
Ambient Storage Humidity	80%RH max. (No Condensation)		

https://www.sunmulon.co.jp/english/products/switch_e/ph.html



◇Dimensions : page PH-3~5

◇Ordering code : page PH-6

◇Panel cutout : page PH-8

SPECIFICATIONS

		Square	Rectangle	Round
Housing	With Flange	A	N/A	N/A
	Without Flange	A	A	A
	With Dress Guard	N/A	N/A	A
Mounting	Snap-in	A	N/A	N/A
	Nut Fixing	A	A	A
Contact	SPDT	A	A	A
	DPDT	A	A	A
Terminal	Soldering	A	A	A
	PCB	A	A	A
RoHS (10 Substances)		Conform to standards		

A : Applicable N/A : Not applicable

CONTACT RATINGS

● Silver contact (Gold-plated)









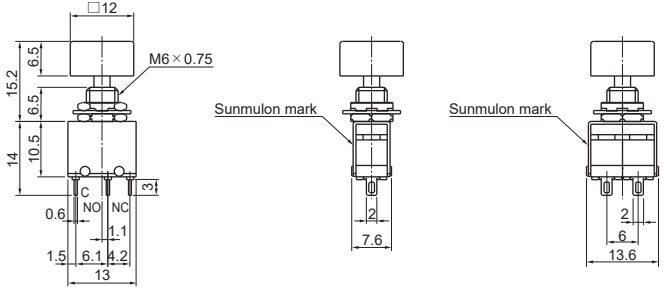

Voltage	Current (A) (Resistive load)
AC 125 V	5
250 V	5
DC 8 V	2
14 V	2
30 V	1
125 V	0.3

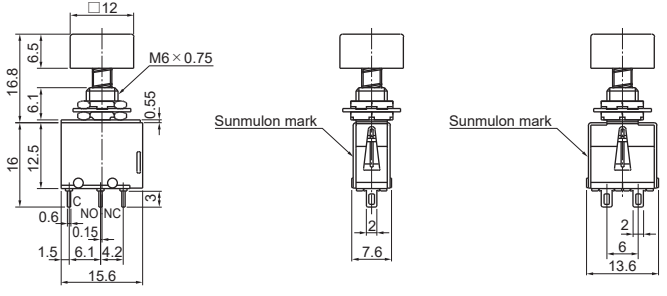
● Cross-bar contact

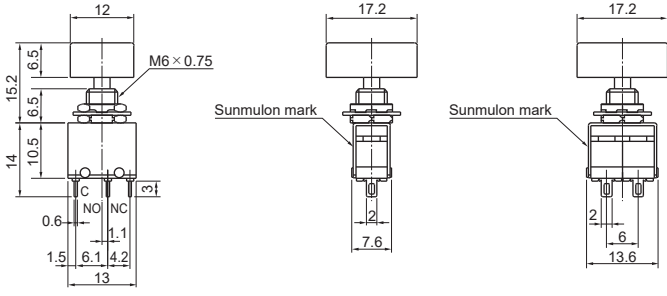
Rating	AC 125 V 0.1 A (Resistive load)
	DC 30 V 0.1 A (Resistive load)
Minimum applicable load	DC 5 V 1 mA (Resistive load)

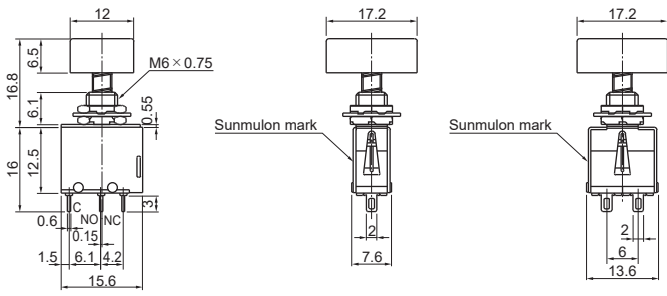
DIMENSIONS

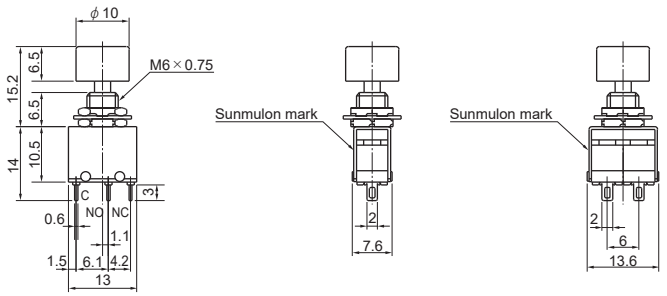
● Nut Fixing Rear Mount

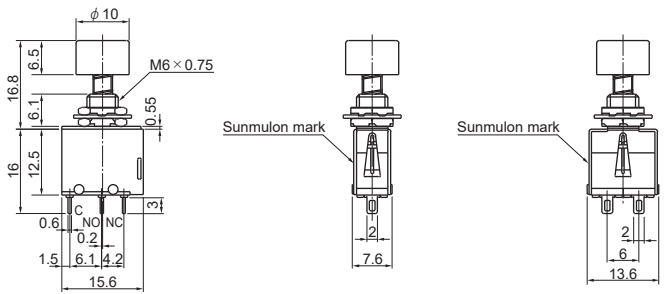





Square	Momentary  3D DXF	
	Alternate  3D DXF	
Rectangle	Momentary  3D DXF	
	Alternate  3D DXF	
Round	Momentary  3D DXF	
	Alternate  3D DXF	

3D • DXF data download site : <https://www.sunmulon.co.jp/download/>

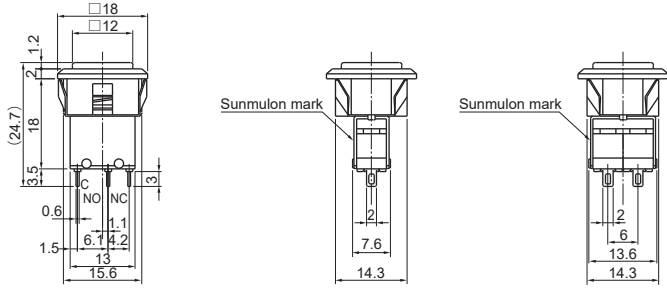
Tolerance : ± 0.4 mm

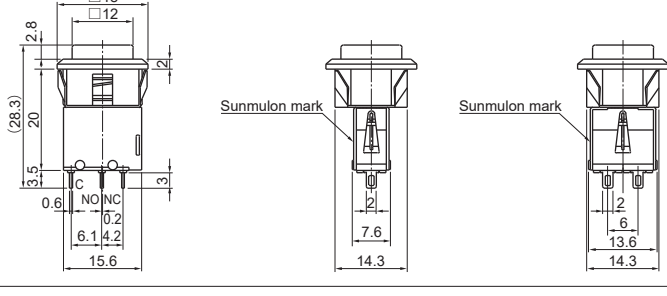
DIMENSIONS

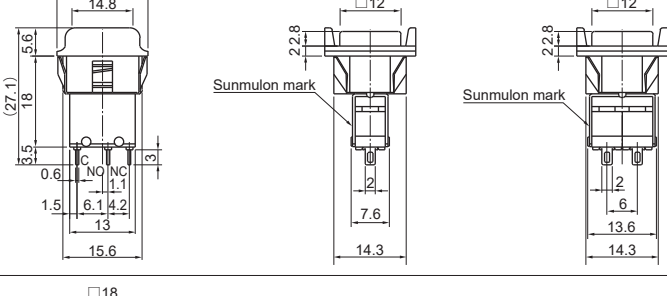
● Snap-in Front Mount

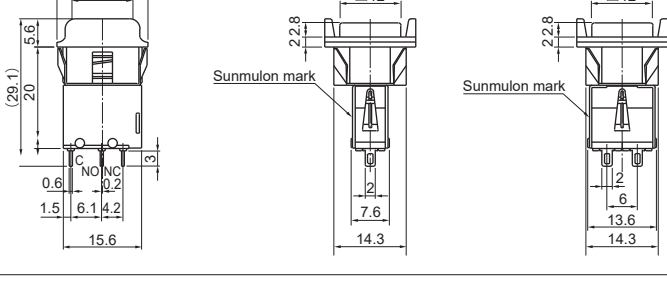
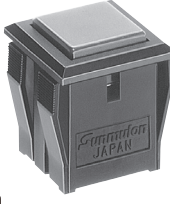
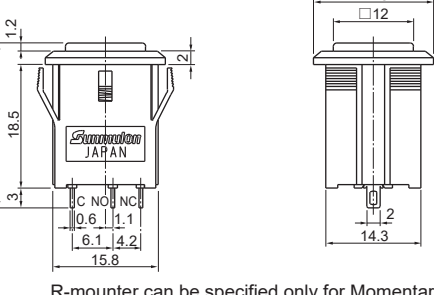
Square S-mounter	Momentary  3D DXF	
	Alternate  3D DXF	
Square V-mounter	Momentary  3D DXF	
	Alternate  3D DXF	
Square R-mounter	Momentary  3D DXF	



R-mounter can be specified only for Momentary, SPDT and soldering terminal.

3D · DXF data download site : <https://www.sunmulon.co.jp/download/>

Tolerance : ± 0.4 mm

DIMENSIONS

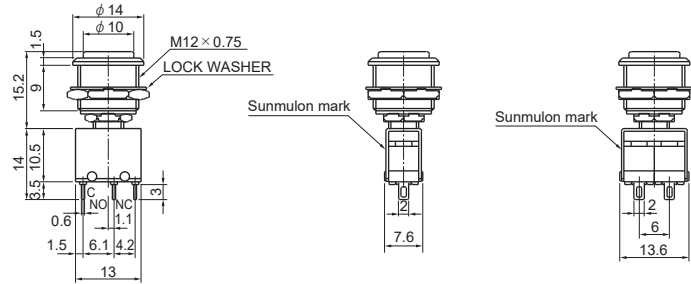
● Nut Fixing Front Mount

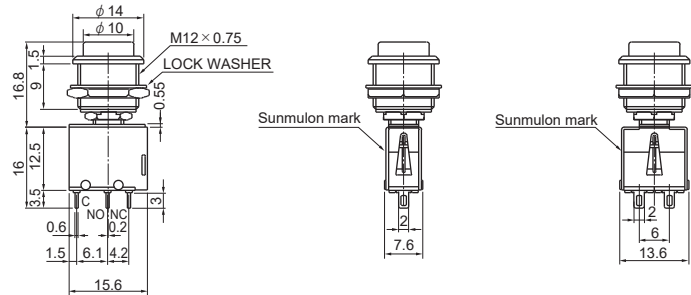
Round Dress Guard	Momentary  3D DXF	
	Alternate  3D DXF	

3D • DXF data download site : <https://www.sunmulon.co.jp/download/>

Tolerance : ± 0.4 mm

ORDERING CODE

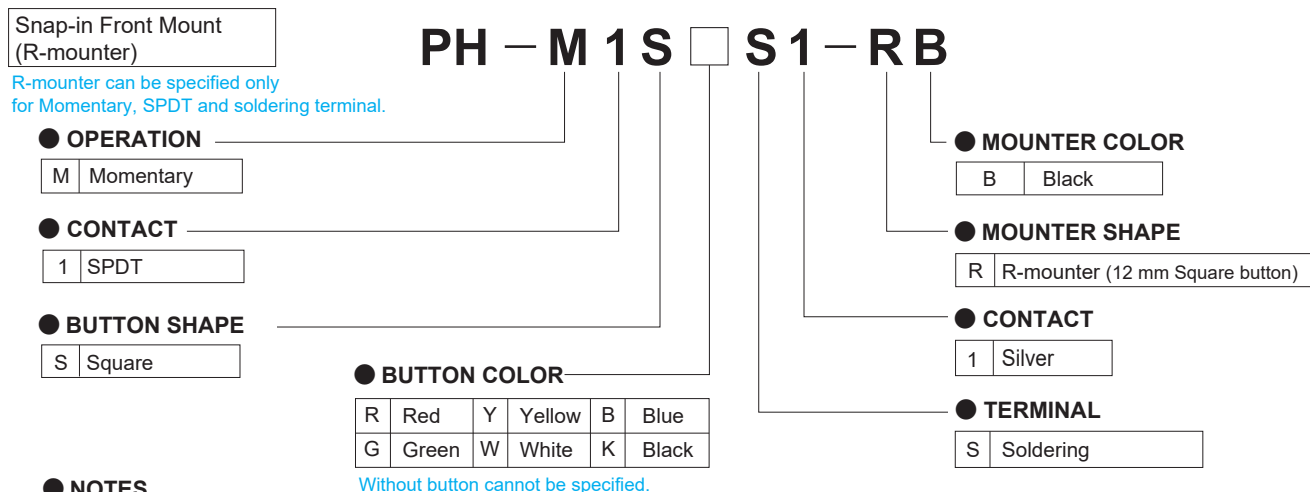
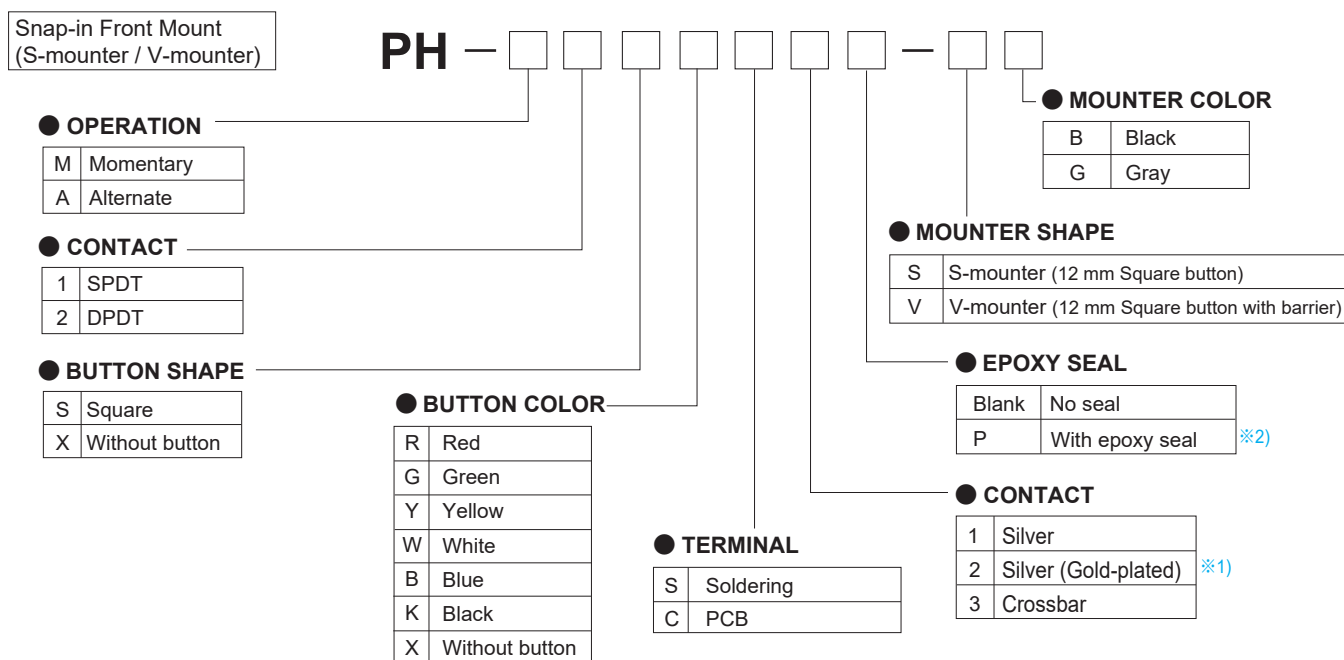
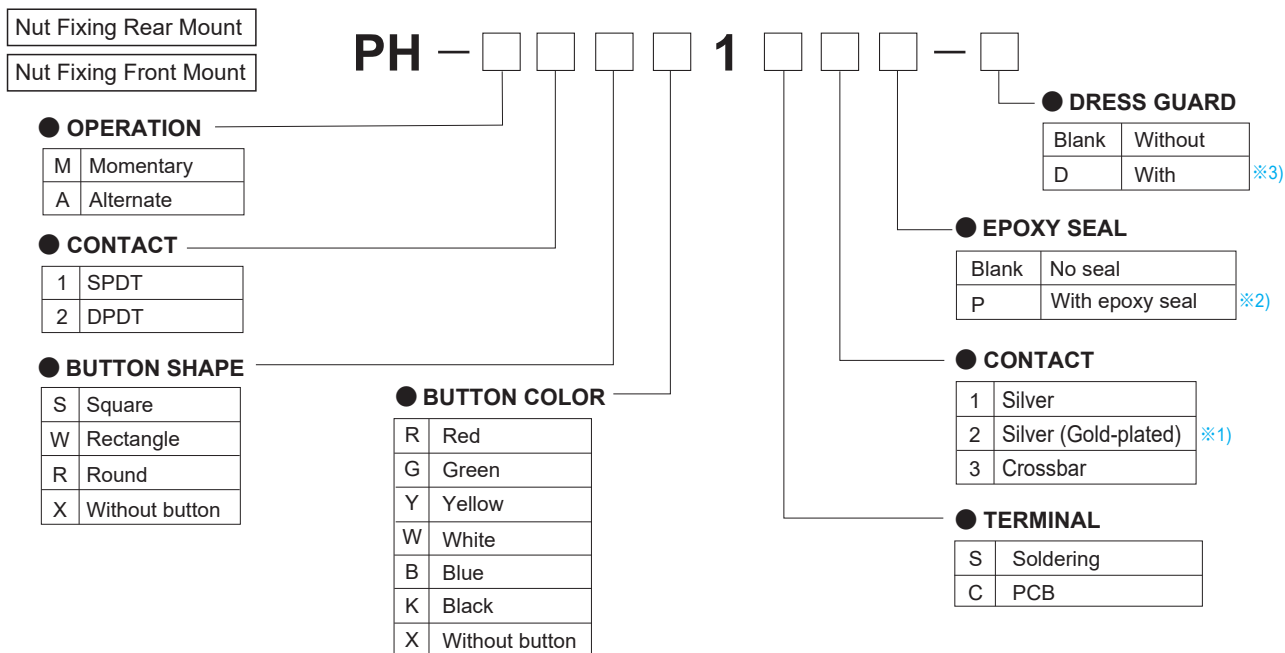

● NOTES

- ※1) For Silver (Gold-plated) contact, K is marked on the part to distinguish from Silver contact.
- ※2) With Flux-prevention.
- ※3) Only 10 mm Round button can be specified.

REPLACEMENT PARTS

● BUTTON

	Red	Green	Yellow	White	Blue	Black
Square	PH-316-R	PH-316-G	PH-316-Y	PH-316-W	PH-316-B	PH-316-K
Rectangle	PH-0390-R	PH-0390-G	PH-0390-Y	PH-0390-W	PH-0390-B	PH-0390-K
Round	PH-238-1R	PH-238-1G	PH-238-1Y	PH-238-1W	PH-238-1B	PH-238-1K

● DRESS GUARD

Part no.	PH-237
----------	--------

Only 10 mm Round button can be specified.

PCB HOLE CUTOUT

● PCB hole cut-out (TOP VIEW)

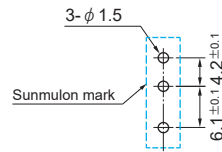

SPDT

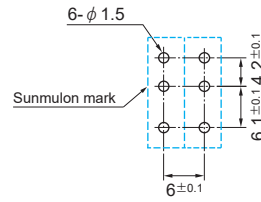

DPDT

TERMINAL SHAPE

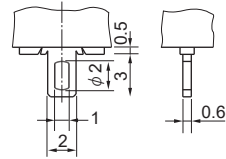

Soldering Terminal

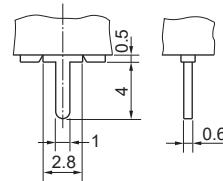

PCB Terminal

Tolerance : ± 0.4 mm

PANEL CUTOUT

● Snap-in Front Mount (S-mounter / V-mounter / R-mounter)

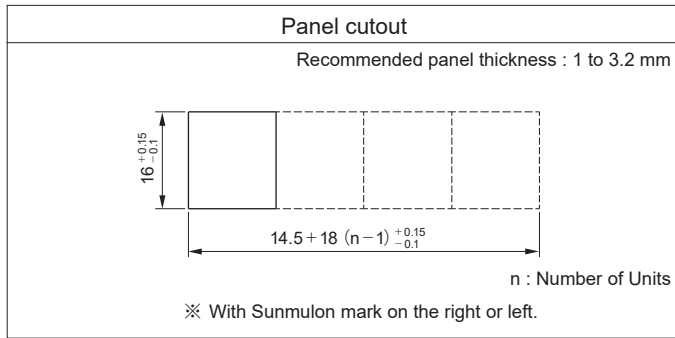

● Panel cut spacing dimensions for spaced individual mounting

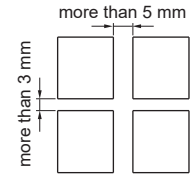

※ With Sunmulon mark on the right or left.

● Nut Fixing Rear Mount

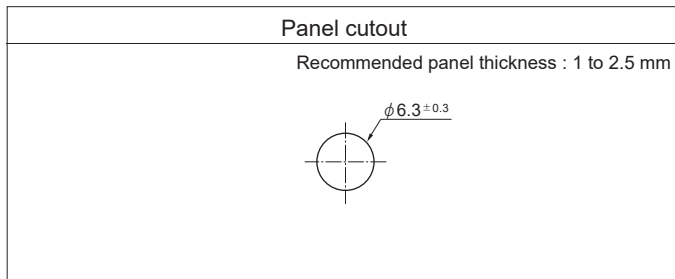

● Nut Fixing Front Mount (Dress Guard)

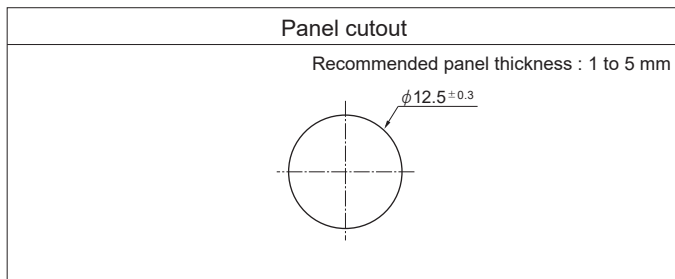

- ※ If the panel is to be finished (e.g. coated), make sure that the panel meets the specified dimensions after the coating.
In case the panel cut dimension is too small, it may cause malfunction.
- ※ After the panel-cutting process, make sure to remove burrs on the surface.

Tolerance : ± 0.4 mm

ASSEMBLY & DISASSEMBLY

1. Removing Button

Insert a screwdriver or similar tool into the bottom of the button while checking through the window in the part and push up the button.

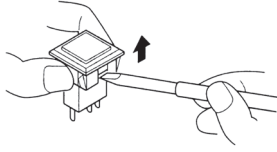

2. Fitting Button

Align the oval part of the center hole inside the button with the oval of the shaft of the part and fit it in.

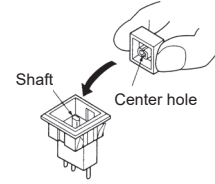

3. Fitting Nut Fixing Rear Mount / Nut Fixing Front Mount

For panel mounting, tighten the hex nuts with a wrench.

Rear Mount

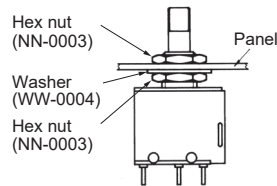

Front Mount (With Dress Guard)

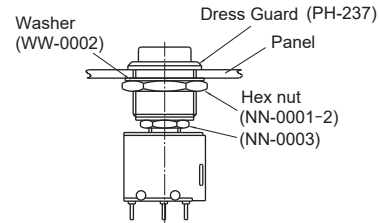

※ Adding 013 to the end of the ordering code, 1 more Hex nut (NN-0003), total 2pcs, will be fitted for dress guard mounting.

PRECAUTIONS FOR CORRECT USE

1. Solder quickly and correctly at 380°C max. and for 3 seconds or less.
Be careful not to touch the soldering iron to the main body.
2. Wait for one minute during and after soldering before exerting any external force on the solder.
3. For Nut Fixing type, the tightening of the mounting nut when attaching to the panel should be 0.69 N·m or less.
4. For Alternate type, a part of the locking mechanism is exposed.
Be careful not to deform the locking mechanism with warm air etc., when covering the switch terminal with a protective tube.

※ For handling instructions and precautions other than the above, please refer to "Safety Precautions for All Illuminated Pushbutton Switches".

Tolerance : ± 0.4 mm

As of July 2023

Safety Precautions for All Illuminated Pushbutton Switches

1. Notes on contents of Catalogs

- (1) Rated values, performance values, and specification values of Sunmulon products listed in this catalog are values acquired under respective conditions in independent testing, and do not guarantee values gained in combined conditions.
- (2) The ambient operating temperature(humidity) is guaranteed by evaluation based on characteristics, and does not guarantee continuous use for a long period of time near the upper or lower limit of the ambient operating temperature(humidity) or permanent use at that temperature(humidity).
- (3) Reference data and reference values listed in catalogs are for reference purposes only, and do not guarantee that the product will always operate appropriately in that range.
- (4) The specifications / appearance and accessories of Sunmulon products listed in catalogs are subject to change or termination of sales without notice, for improvement or other reasons.
- (5) The content of catalogs is subject to change without notice.

2. Note on applications

- (1) If using Sunmulon products in combination with other products, confirm the following suitability by yourself. Sunmulon shall provide no guarantees regarding the combination suitability.
 - (a) Regulations, standards, or laws to which your machinery, equipment, etc. must conform
 - (b) Functionality and safety of your machinery and equipment
- (2) Wiring and installation that ensures the Sunmulon product used in your system, machine, device, or the like can perform and function according to its specifications.
- (3) When using Sunmulon products, be cautious when implementing the following.
 - (a) Use of Sunmulon products with sufficient allowance for rating and performance.
 - (b) Safety design, including redundant design and malfunction prevention design that prevents other danger and damage even in the event that Sunmulon product fails.
- (4) Sunmulon products are designed and manufactured as general-purpose products for general industrial products. They are not intended for use in the following applications, and in the event that you use Sunmulon product for these applications, unless otherwise agreed upon between you and Sunmulon, Sunmulon shall provide no guarantees whatsoever regarding Sunmulon products.
 - (a) Safety devices intended for human body protection
 - (b) Direct control of transport equipment (railroads / airplanes / ships / vehicles / vehicle instruments, etc.)
 - (c) Space equipment, submarine equipment
 - (d) Nuclear power control equipment, radiation related equipment
 - (e) Combustion equipment, electric heat equipment
 - (f) Disaster prevention and security equipment
 - (g) Elevating equipment
 - (h) Amusement facilities
 - (i) Facilities subject to government or industry regulations
 - (j) Use in applications that require a high degree of safety, any other equipment, instruments, or the like that could endanger life or human health

3. Warranty

- (1) The warranty period for Sunmulon products shall be 1 year after purchase or delivery to the specified location.
- (2) Warranty scope should a failure occur in Sunmulon product during the above warranty period for reasons attributable to Sunmulon, then Sunmulon shall provide that product, free of charge, the same quantity. Further, in no event shall liability of Sunmulon exceed the individual price of the product on which liability is asserted.
- (3) Failures caused by the following reasons shall be deemed outside the scope of this warranty.
 - (a) The product was handled or used deviating from conditions / environment listed in the catalogs
 - (b) The failure was caused by reasons other than Sunmulon product
 - (c) Modification or repair was performed by a party other than Sunmulon
 - (d) Replacement of maintenance parts, installation of accessories, or the like was not performed properly in accordance with the user's manual and catalogs
 - (e) The failure could not have been predicted with the scientific and technical standards at the time when the product was shipped from Sunmulon
 - (f) The failure was due to other causes not attributable to Sunmulon (including cases of force majeure such as natural disasters and other disasters)
- (4) The warranty listed in this Safety Precautions is the full and complete warranty for Sunmulon products, and Sunmulon shall bear no liability whatsoever regarding special damages, indirect damages, incidental damages, or passive damages that occurred due to Sunmulon product.

4. Handling precautions for switch

- (1) Do not perform wiring with power supplied to the switch. Do not touch the terminals or other charged parts of the switch while power is being supplied. Doing so may result in electric shock.
- (2) Be careful of electrostatic breakdown when handling.
- (3) Do not drop or otherwise apply strong force to the switch.
- (4) Do not place heavy objects on the switch.
- (5) Do not operate or use the housing (switch unit) by itself. Use the switch with assembled the illuminated part (LED module or button).
- (6) Pushbutton switches are designed to be operated by fingertips. Operating the switch using a sharp object (screwdrivers, tweezers, etc.), hard object (metal, etc.), or with a large or sudden force, may cause deform or damage the switch.
- (7) Do not use the switch under loads that exceed the rated switching capacity or other contact ratings. Doing so may result in welding of the contact, or burnout accidents.

Safety Precautions for All Illuminated Pushbutton Switches

(8) For inductive load, the arc by back EMF may cause contact failure. Insertion of arc prevention circuit as the following is recommended.

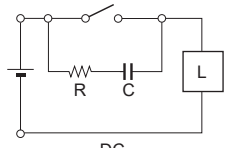
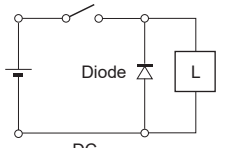
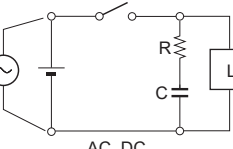
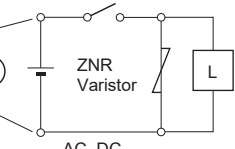
Circuit	Element selection	Circuit	Element selection
 <p style="text-align: center;">DC</p>	<p>C : 1 to 0.5 μF \times switch current (A) R : 0.5 to 1 Ω \times switch voltage (V)</p> <p>The values may change according to the characteristics of the load. Determine ideal capacitance and resistance values through testing.</p>	 <p style="text-align: center;">DC</p>	<p>The diode must withstand a peak inverse voltage 4 times higher than the power supply voltage and regarding a forward current must as high or higher than the load current.</p>
 <p style="text-align: center;">AC, DC</p>	<p>The values may change according to the characteristics of the load. Determine ideal capacitance and resistance values through testing.</p>	 <p style="text-align: center;">AC, DC</p>	<p>Use a varistor that can withstand the power supply voltage sufficiently. (1.5 times or more)</p>

(9) Following circuits show examples of an anti-chattering circuit.

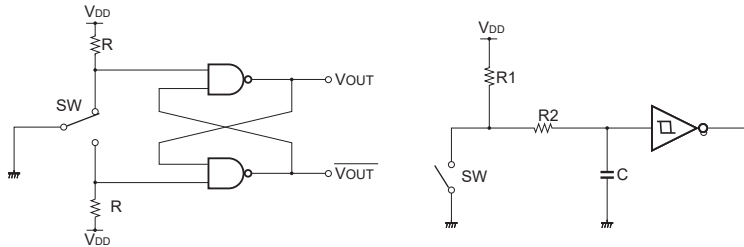

(10) Illumination

- (a) Do not apply a voltage between the LED terminal that is greater than the rated voltage. Doing so may damage the LED, cause lighting failure.
- (b) LEDs cannot be lit directly by AC circuit should be provided rectifier smoothing circuit for products other than AC input type.

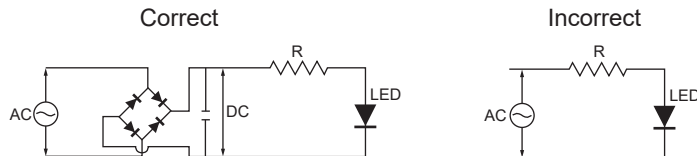

- (c) When wiring, pay attention to the polarity of the terminals.
- (d) Simultaneous lighting may not be possible with Dual-Color illumination or Split-Face illumination (2, 3, or 4 split illumination), check the catalog.
- (e) Apply voltage directly to LEDs of Non-built-in resistor type will damage the LEDs, so connect an appropriate external resistor.

(11) Wiring

- (a) Do not apply a soldering iron to the switch housing. Doing so may deform the terminals and cause defects.
- (b) See catalog for models compatible with flux prevention measures terminal. Be careful not to allow flux to penetrate sliding parts such as buttons. Use non-corrosive rosin solution as flux for dip soldering.
- (c) For soldering other than flux-preventive models, hand solder with the terminals facing down to prevent flux from penetrating into the switch.

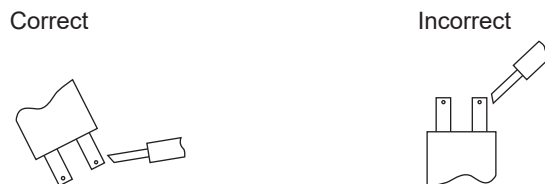

- (d) The housing of KA, K2, and K9 series are designed for reflow soldering.
- (e) Use the appropriate wire size for the applied voltage and current, and solder properly. Use of the product with incomplete soldering may cause abnormal heat generation, resulting in a fire hazard.
- (f) After wiring is completed, maintain an appropriate insulation distance.

Safety Precautions for All Illuminated Pushbutton Switches

(12) Usage environment

- (a) Do not use in the presence of flammable or explosive gases such as gasoline, thinner, LPG, etc.
- (b) Avoid using the product in places where corrosive or silicon gas is generated, high temperature, high humidity, sea breeze or direct sunlight.
- (c) Provide appropriate protection when using the product in places where it is exposed to water, oil, metal powder, or dust.
- (d) Do not use the product in a place subject to vibration or shock. It may cause malfunction or damage.
- (e) When installed in a close grouping or continuously lit, the ambient temperature may exceed the specified value due to heat generation. Take measures such as ventilation and lowering the operating voltage.
- (f) When checking the actual equipment, load conditions and operating environment should be the same as the actual operating conditions.
- (g) The ambient temperature for storage is -25°C to 65°C (No freeze, no condensation).

(13) When wiping off dirt on the exterior of the switch and accessories such as side plates, wipe lightly with a soft, dry cloth. Organic solvents such as thinner, benzene, alcohol, or other acidic chemicals may cause deformation, discoloration, or malfunction.

(14) Store the product away from malignant gases, dust, high temperature and high humidity, and keep it in our packing condition.

(15) When removing the illuminated part (or button) from the alternate switch housing, switch state should be in a free state.

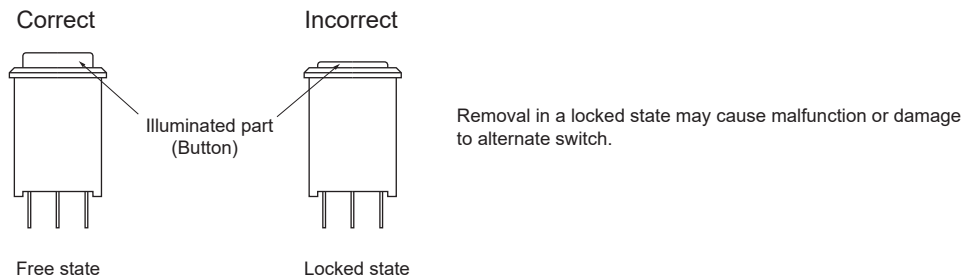

(16) Periodic inspection and replacement

- (a) Although mechanical and electrical durability are listed in the specifications column, deterioration of various parts (deterioration of resins and corrosion of metal parts) is possible due to the operating environment and method of use. We ask that you implement inspections for Sunmulon products to prevent accidents from occurring by conducting periodic inspections and replacements.
- (b) When the switch is left unused or stored for long periods, contact reliability may deteriorate due to oxidation of contacts, which may cause continuity failure, etc. Therefore, it is necessary to check the operation before use.

(17) Service scope

The price of Sunmulon products do not include the cost of services, such as dispatching technicians.